

39.3300
UNDERMOUNT
SERIES
INSTALLATION

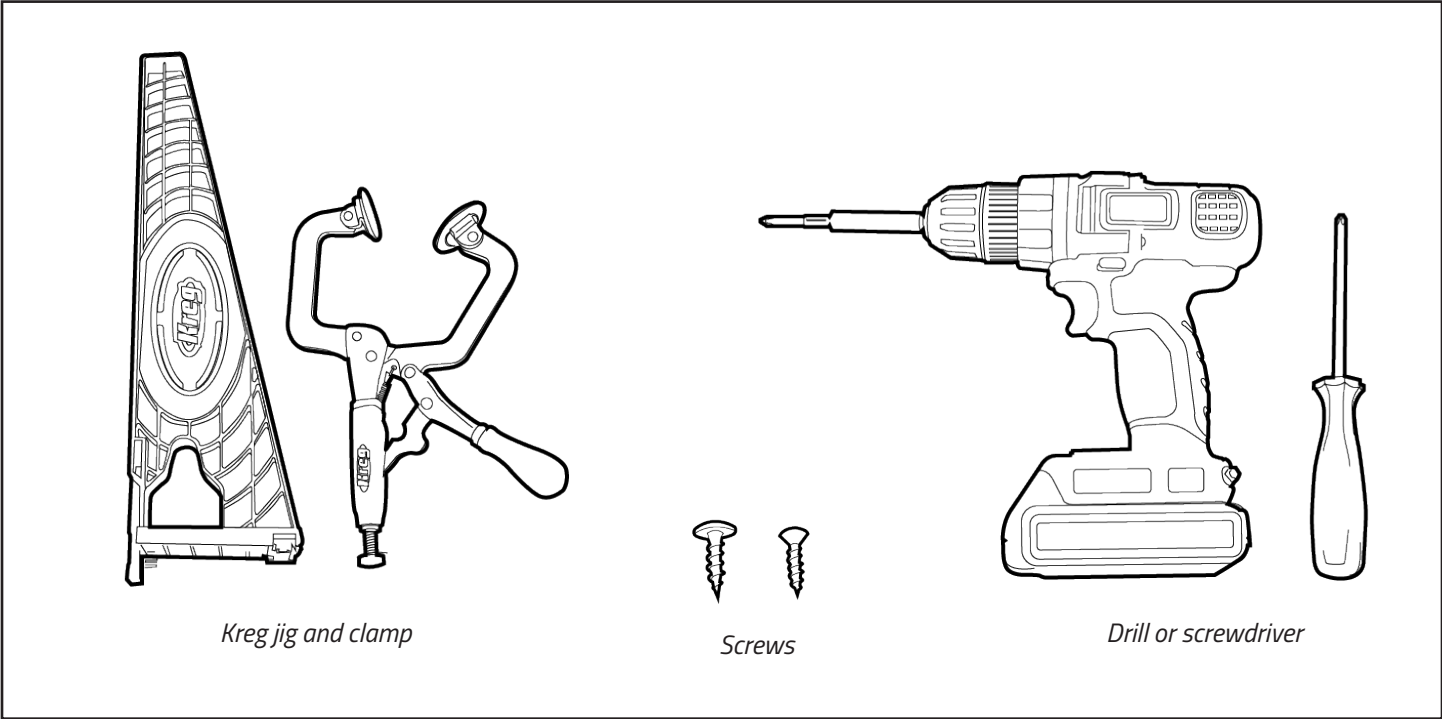

Tools and Hardware Recommended:



Hardware Included:

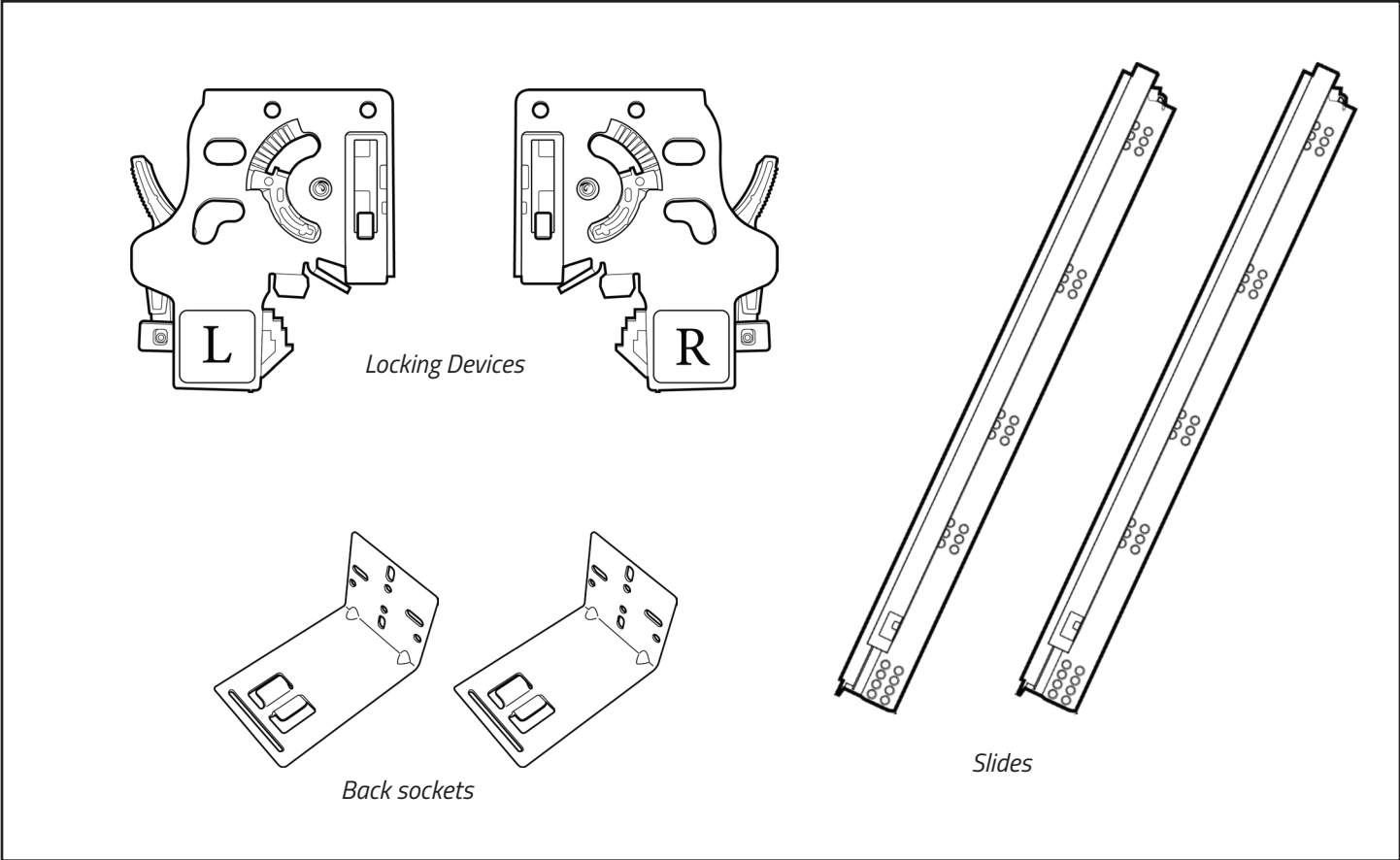

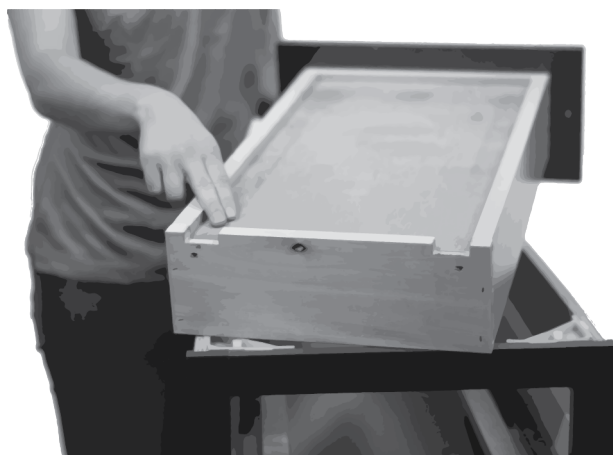

STEP 3)

Cut notches for the slides, and drill 6mm (1/4") hole for the slide hook into the back of the drawer box.

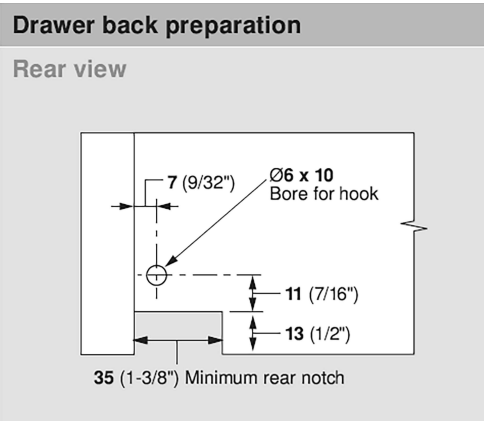

STEP 4)

Install locking devices, which should align inside the bottom front of the drawer box. Screw them into place. Avoid screwing the devices into the bottom of the draw box to keep the screws from puncturing the drawer.

Installing the Slides

STEP 5a)—Face Frame

We recommend that you use a jig (such as a Kreg Drawer Slide Jig) to make sure you install the slide square and level. If you don't have one, however, you can make do with careful measuring and marking. Screw the slide to the face frame first, setting the slide back $\frac{1}{8}$ " from the front edge of the cabinet (to allow room for the drawer to close). Next, after verifying that the slide is level, screw the back socket to the back of cabinet.





STEP 5b) — Frameless

Frameless: For a frameless cabinet, simply screw the slide into the side of the cabinet, also setting it back 1/8". Again, using a jig will make it easier to keep the slide level, but measuring and marking will also work.

Note: image depicts a face frame cabinet that has been modified to demonstrate frameless installation.



STEP 6)

Place the drawer on the rails, paying attention to line up the notches and holes in the back of the drawer.

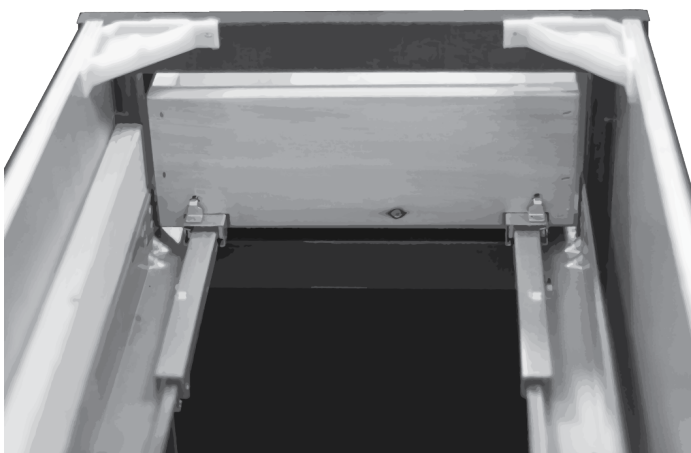

STEP 7)

Push the drawer to the back of the cabinet until you hear it lock into place.

*If you need more information or help installing your drawer slides, please give us a call at **262-375-7960***

